

1959 – 1960

Chevrolet

Installation Manual

TABLE OF CONTENTS

| | |
|---|----|
| Welcome from the Team at Classic Instruments! | 3 |
| Mount Adapter Ring..... | 4 |
| Mount New 4-5/8" Gauge in Center Gauge Pod | 4 |
| Mount New 2-1/8" Gauges in Side Gauge Pods | 5 |
| Speedometer Wiring | 5 |
| Speedometer Signal Interface [SN74] Wiring | 6 |
| Tachometer Wiring..... | 7 |
| Wiring Diagrams | 9 |
| 4-5/8" Speedometer | 9 |
| Speedtachular Combo Gauge..... | 10 |
| 16 Pulse Signal Generators [SN16] | 11 |
| Speedometer Signal Interface [SN74] | 11 |
| Fuel, Oil Pressure, Temperature & Volt Gauge Wiring | 13 |
| Universal Fuel Level Sender Installation..... | 15 |

Welcome from the Team at Classic Instruments!

Our congratulations and appreciation for your purchase of one of the finest quality sets of specialty instruments ever produced! Your instrument set has been conceived, designed, and manufactured by Classic Instruments, Inc. in the U.S.A. Each instrument has been tested and certified for accuracy and quality before packaging and shipping.

For trouble-free installation and operation follow the instructions exactly as outlined. Your instruments were assembled to precise specifications and although each has a five (5) year warranty covering defective parts and workmanship – this warranty will not cover instruments or sender units which have been installed incorrectly.

Follow our recommended procedures for installation and proper hookup to maintain the value and appearance of your instrument set during many future years of accurate and dependable service!

LIMITED WARRANTY

Classic Instruments, Inc. (CI) warrants to the original purchaser that any CI product manufactured or supplied by CI will be free from defects in material and workmanship under normal use and service for a period of five (5) years from date of purchase.

Improper installation, use of sending units other than CI's or attempted repair or adjustments by other than CI shall void this warranty. Disassembly of any instruments or senders for whatever reason shall specifically void this warranty.

It's always easy to look to a part for an issue with your set. Before you conclude that a part may be bad, thoroughly check your work. Today's semiconductors and passive components have reached incredibly high reliability levels, but there is still room for error in our human construction skills. However, on rare occasions a sour part can slip through. Please be aware that testing can usually determine if the part was truly defective or damaged by assembly or usage. Don't be afraid of telling us that you "blew it", we're all human and in most cases, replacement parts are very reasonably priced.

Purchaser requesting a product to be repaired or replaced under warranty must first call CI at 1-800-575-0461 before the return of defective part. Send defective part either to 826 Moll Drive, through UPS, or to P.O. Box 411 through U.S. Mail, Boyne City, MI 49712, USA. Include a written description of the failure with defective part.

Purchaser agrees and accepts that under no circumstances will a warranty replacement be furnished until CI has first received, inspected, and tested the returned part.

All other warranties expressed or implied are hereby excluded including any implied warranty of merchandise and implied warranty of fitness for a particular purpose. The sole and exclusive remedy for breach of this warranty is limited to the replacement set forth above.

It is expressly agreed that there shall be no further remedy for consequential or other type of damage, including any claim for loss of profit, engine damage or injury.

TECHNICAL ASSISTANCE

1-800-575-0461

OR

Visit our website for the latest in gauge design and updates to our installation manual

www.classicinstruments.com

Mount Adapter Ring

- 1) Remove the original speedometer from the center gauge pod.
- 2) Install the new adapter ring in the center gauge pod. Secure the adapter using the three supplied mounting brackets. See Fig. 3



Fig. 1: Adapter Ring & Mounting Brackets



Fig. 2: Center Gauge Pod

Mount New 4-5/8" Gauge in Center Gauge Pod

- 1) Insert the new gauge, from the front, into the center gauge pod. Secure the new gauge using the "U" shaped mounting bracket. See Fig. 3

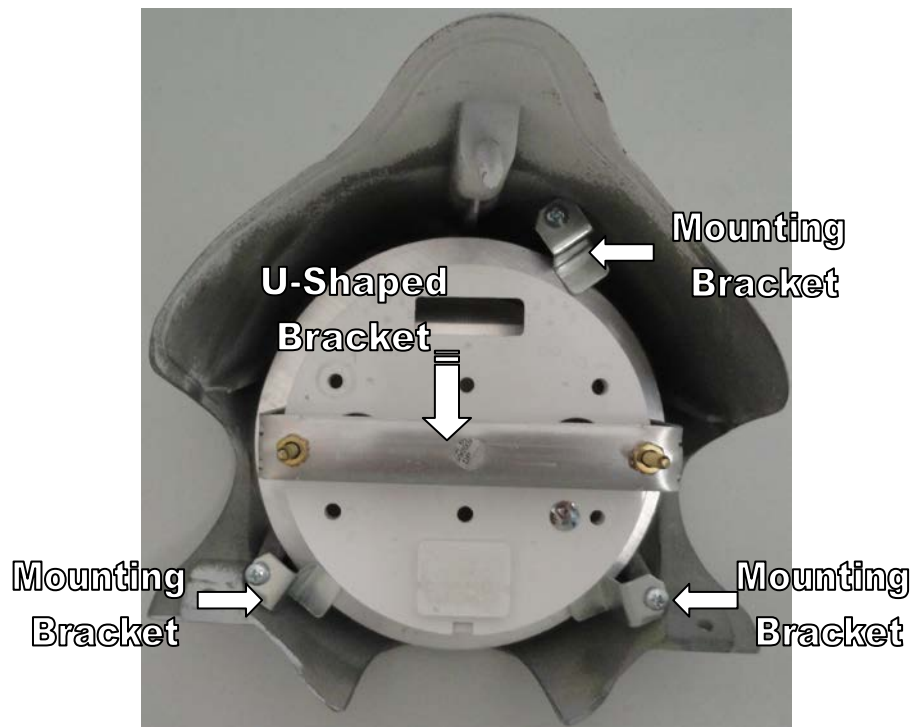
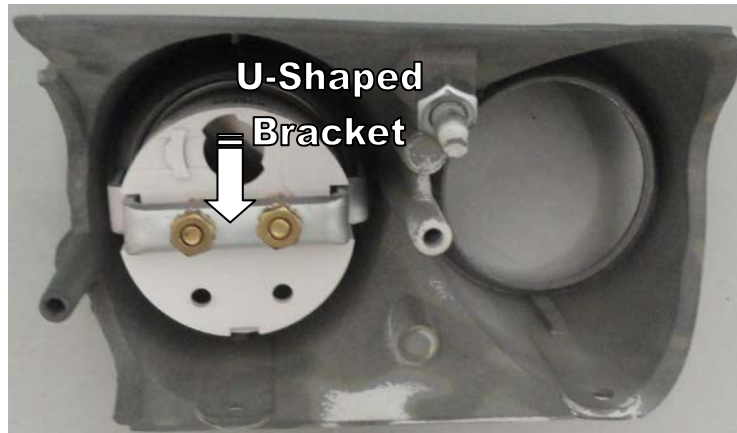

Fig 3: Assembled Center Gauge Pod

Mount New 2-1/8" Gauges in Side Gauge Pods

- 1) Remove the original gauges from the two side gauge pods.
- 2) Insert the new gauges, from the front, into the two side gauge pods. Secure the new gauges using the "U" shaped mounting brackets.



Partially Assembled Side Gauge Pod

Speedometer Wiring

- 1) Always disconnect the vehicle battery before wiring any gauge.
- 2) Connect a switched +12VDC power source to the "1" terminal on the back of the speedometer or "**DEDICATED SWITCHED +12VDC**" terminal on the black control box of the speedtachular gauge combo. *We recommend using a dedicated power source for the speedometer to avoid possible problems caused by bad "noisy" power.*
- 3) Connect a good chassis ground to the "2" terminal on the back of the speedometer or "**DEDICATED GROUND**" terminal on the black control box of the speedtachular gauge combo. *We recommend using a dedicated chassis ground (not stacked with other ground wires) to avoid possible problems caused by a bad ground.*
- 4) Connect dash light power to:
 - a. Terminal "6" on a 4-5/8" speedometer.
[OR]
 - b. **Brown** wire from 4-pin plug on the back of a speedtachular gauge combo.
- 5) Connect the speed signal to the "3" terminal on the back of the speedometer or "**SPEED SIGNAL**" terminal on the black control box of the speedtachular gauge combo:
 - a. White signal wire from a signal generator (SN16)
[OR]
 - b. Output from a SN74 speedometer calibration box

- 6) Connect the speed signal ground to the “2” terminal on the back of the speedometer or “**DEDICATED GROUND**” terminal on the black control box of the speedtachular gauge combo:
 - a. Black wire from a signal generator (SN16)
[OR]
 - b. Ground from a SN74 speedometer calibration box
- 7) Connect the speed signal power to the “1” terminal on the back of the speedometer or “**DEDICATED SWITCHED +12VDC**” terminal on the black control box of the speedtachular gauge combo:
 - a. Red wire from a signal generator (SN16)
[OR]
 - b. Power from a SN74 speedometer calibration box
- 8) Connect the #24AWG red wire labeled “**Right Turn**” to your turn signal switch’s right turn indicator power.
- 9) Connect the #24AWG red wire labeled “**Left Turn**” to your turn signal switch’s left turn indicator power.
- 10) Connect the #24AWG red wire labeled “**High Beam**” to your light switch’s high beam indicator power.

Speedometer Signal Interface [SN74] Wiring

- 1) Connect switched +12VDC to “POWER” *(see speedometer wiring step 7)*
- 2) Connect chassis ground to “GROUND” *(see speedometer wiring step 6)*
- 3) Connect the red wire from a SN16 pulse signal generator to “SENSOR PWR”. *(if not using the SN16, do not use this connection)*
- 4) Connect the black wire from a SN16 pulse signal generator OR one wire from the built-in transmission VSS (2-wire) to “SENSOR GND”. *(if using an ECM speed signal, do not use this connection)*
- 5) Connect the white wire from a SN16 pulse signal generator OR one wire from the built-in transmission VSS (2-wire) OR the ECM speed signal to “INPUT”
- 6) Connect “OUTPUT” to the signal terminal of the speedometer. *(see speedometer wiring step 5)*
- 7) Connect “CRUISE” to the signal input for a cruise control module *(if needed)*. The cruise control signal is 8,000 pulses per mile (PPM).
- 8) Connect one lead from the momentary pushbutton to each of the two “PUSHBUTTON” connections.
- 9) Determine the default pulse setting for the speedometer (Classic Instruments speedometer with 8 dip switches is 8,000ppm, Classic Instruments speedometer with 12 dip switches is 16,000ppm)
- 10) If speedometer dip switches are not in the default position, set them at this time (8,000ppm speedometer 2 6 7 8 OPEN, 16,000ppm speedometer 5 6 7 8 OPEN)
- 11) Set switches on the module according to the chart below based on the speed signal you will be using.

| Signal Source | Gauge Type | Switch Setting |
|-----------------------------|----------------------|------------------|
| SN16 Pulse Signal Generator | 8-Pulse (8,000ppm) | 1 2 3 ON – 4 OFF |
| | 16-Pulse (16,000ppm) | 1 2 ON – 3 4 OFF |
| VSS | 8-Pulse (8,000ppm) | 3 ON - 1 2 4 OFF |
| | 16-Pulse (16,000ppm) | 1 2 3 4 OFF |
| ECM | 8-Pulse (8,000ppm) | 1 2 3 ON – 4 OFF |
| | 16-Pulse (16,000ppm) | 1 2 ON – 3 4 OFF |

Switch 1 – OFF = vehicle speed sensor signal, ON = Computer & SN16 signals
Switch 2 – OFF = high sensitivity, ON = low sensitivity
Switch 3 – OFF = 16,000ppm signal output, ON = 8,000ppm signal output
Switch 4 – *Not Used*

Tachometer Wiring

- 1) Always disconnect the vehicle battery before wiring any gauge.
- 2) Connect the tachometer signal to the “**TACHOMETER**” terminal on the black control box of the speedtachular gauge combo.
Refer to the following ignition system types to help determine where to get the signal.

STANDARD POINTS & CONDENSER SYSTEM

Connect the negative side of the coil (usually marked as “-“) to the signal terminal for the tachometer.

GMC – HEI (High Energy Ignition System)

Connect the “TACH” terminal on coil side of distributor cap to the signal terminal for the tachometer.

MSD (Multiple Spark Discharge System)

Connect the TACH signal on the MSD box to the signal terminal for the tachometer. If the tachometer does not respond, your MSD system may require a MSD Tach adapter. Part No. 8910 or 8920.

VERTEX MAGNETO SYSTEM

Connect the “KILL” terminal on the side of a Vertex magneto body to the signal terminal for the tachometer. An external adapter such as an MSD “Pro Mag Tach Converter” #8132 may be required.

ACCEL IGNITION COILS

Connect the negative side of the coil to the signal terminal for the tachometer.
CAUTION! Some Accel ignition coils require the tach signal wire to be connected to the “+” terminal on the coil! PLEASE carefully read Accel’s instructions before connecting ignition coil.

MALLORY IGNITION

Connect the negative terminal side of coil (usually marked as “-“) to the signal terminal for the tachometer.

ECM TACHOMETER SIGNAL

Signal comes from the computer. When using this type of signal, a SN76 tachometer signal adapter is required.

MULTIPLE COIL IGNITION SYSTEMS

A tach adapter is required for these ignition systems. A tach signal driver such as the MSD #8913, which produces a 12V square wave signal, is recommended. Please check with manufacturer for your specific application.

NOTICE! For all other ignition systems please look at the owner’s manual for that system.

- 3) Connect a good chassis ground to the “**GROUND**” terminal at the bottom of the black control box of the speedtachular gauge combo.
- 4) Connect a switched +12VDC power source to the “**+12VDC SWITCHED**” terminal at the bottom of the black control box of the speedtachular gauge combo.

Wiring Diagrams

4-5/8" Speedometer

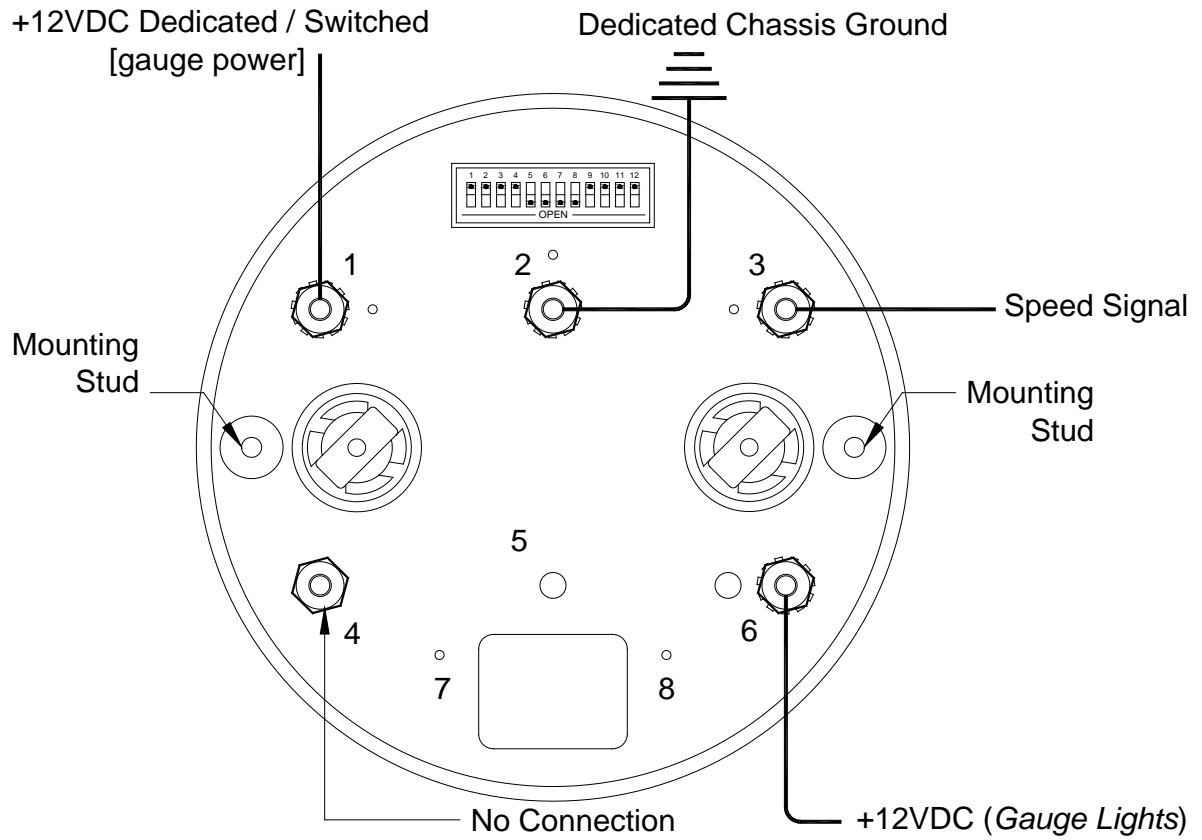

Speedtachular Combo Gauge

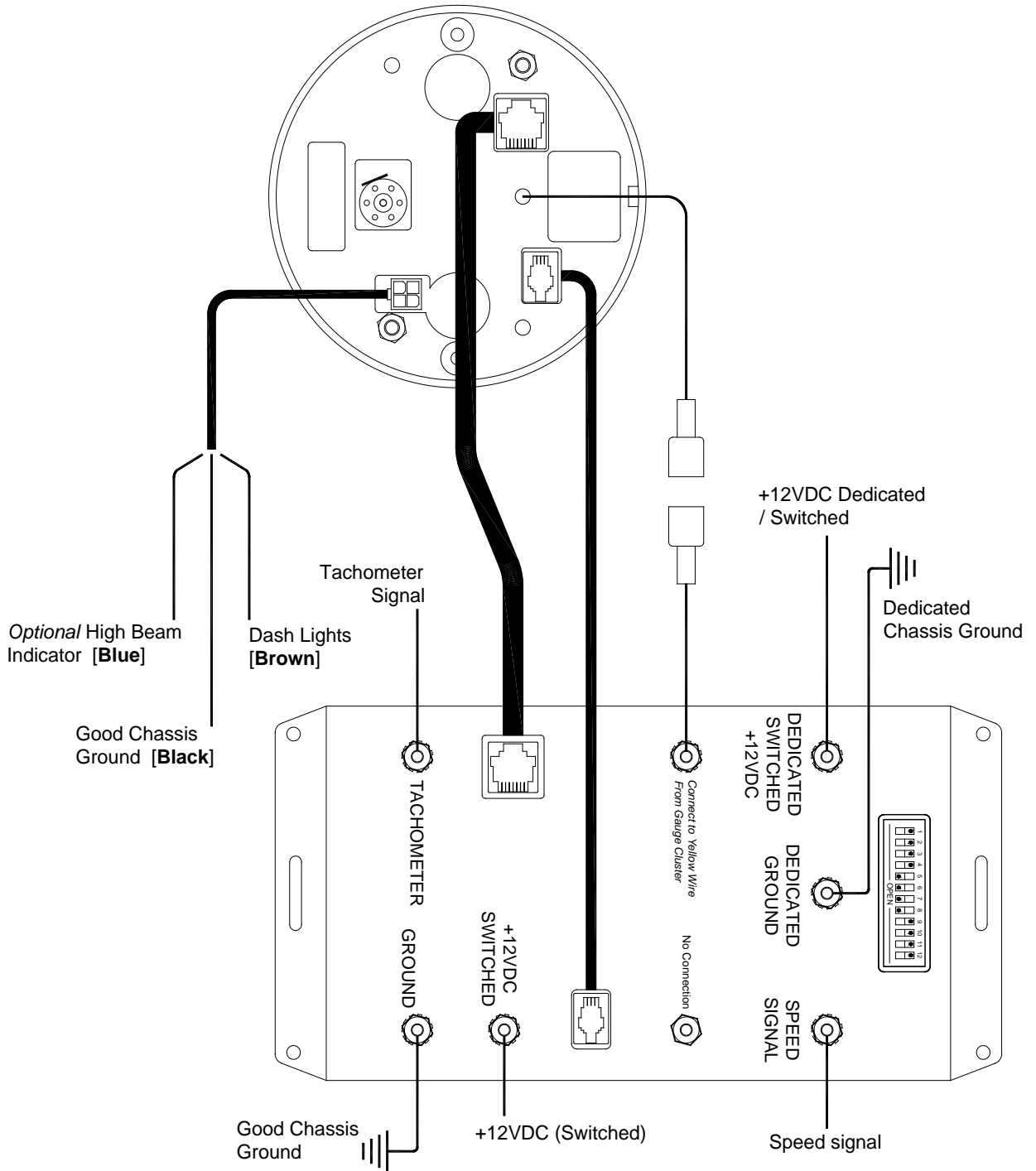

16 Pulse Signal Generators [SN16]

Attach the signal generator to the transmission speedometer gear housing (where the speedometer cable originally connected). Do not use excessive force to tighten. These signal generators produce approximately 16,000 pulses per mile (PPM).

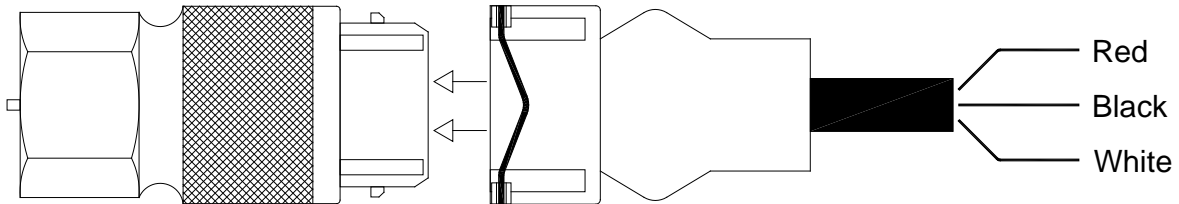

Red: ----- +12VDC
Black: ----- Ground
White: ----- Signal

Speedometer Signal Interface [SN74]

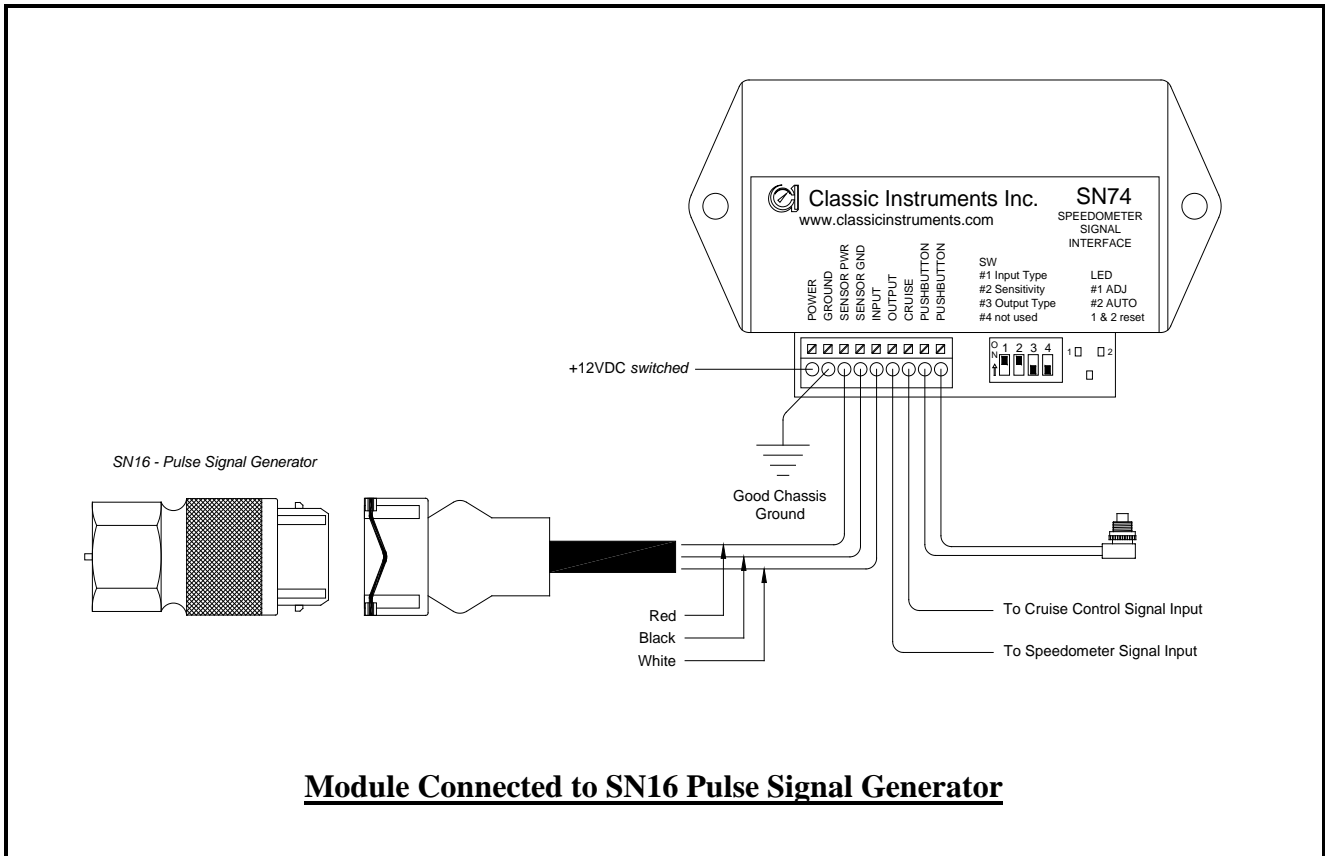

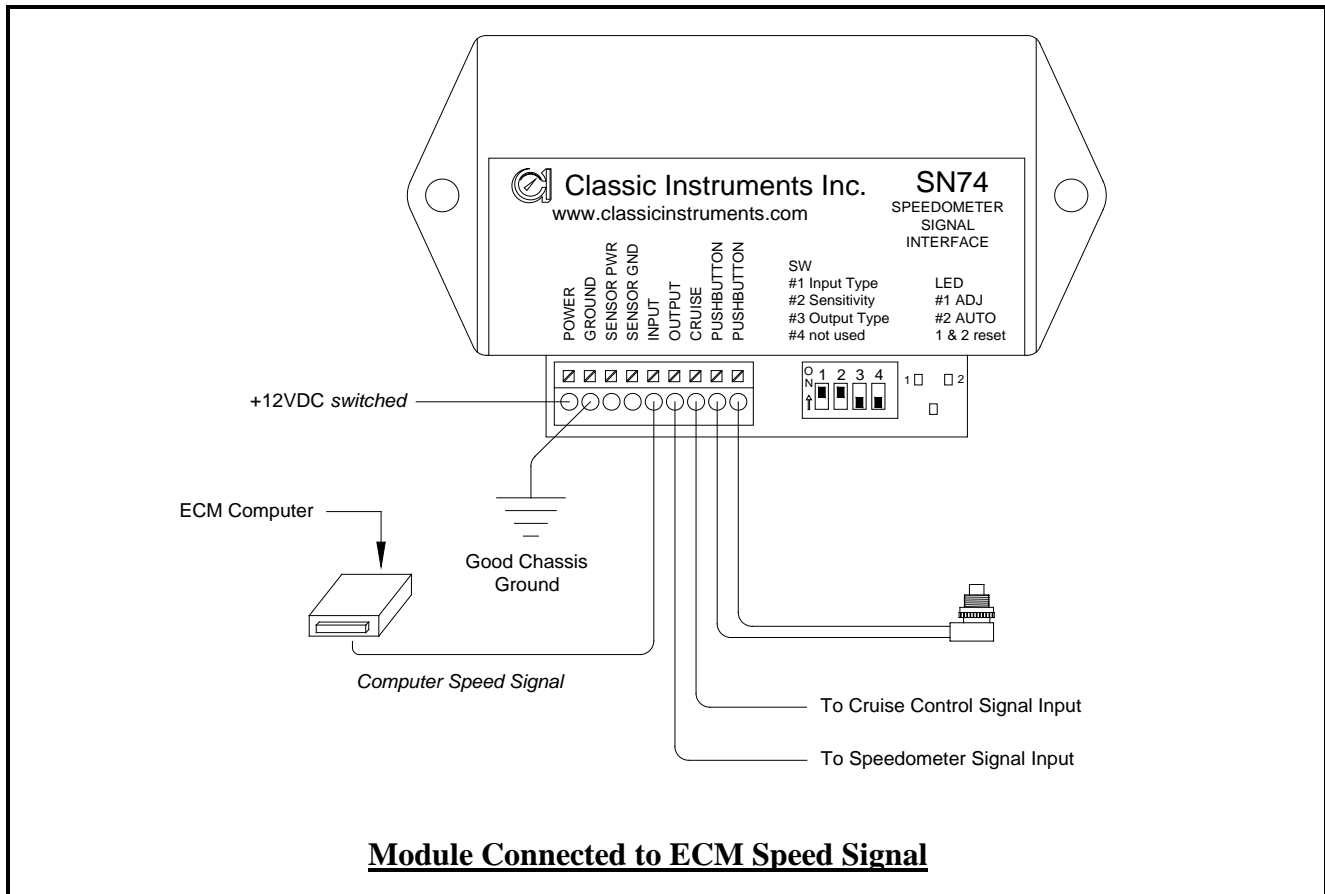
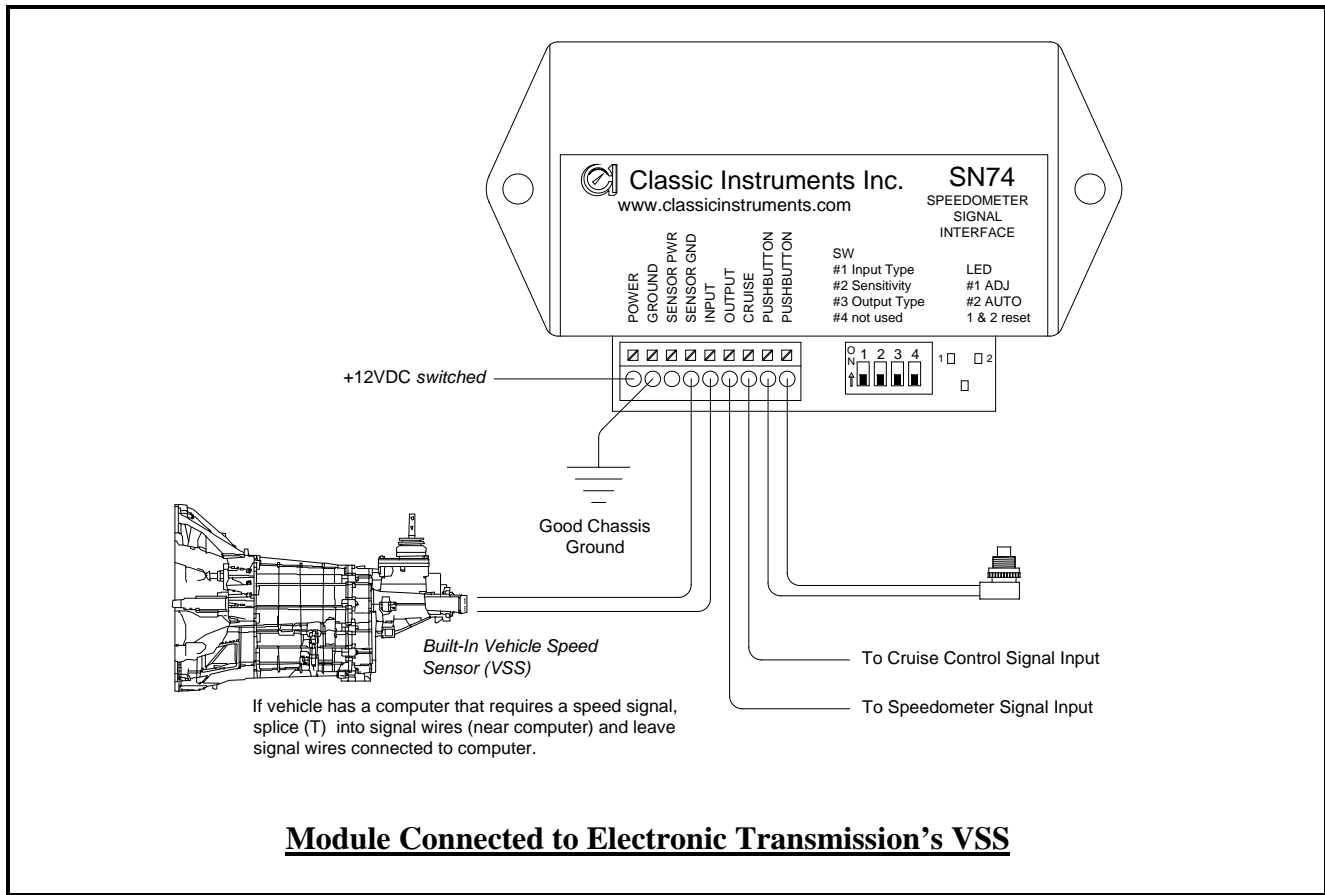

Fuel, Oil Pressure, Temperature & Volt Gauge Wiring

- 1) Always disconnect the vehicle battery before wiring any gauge.
- 2) Connect a switched +12VDC power source to the "I" terminal on the back of each gauge.
- 3) Connect a good chassis ground to the "G" terminal on the back of each gauge. (*the "G" terminal is also one of the terminals used to secure the mounting bracket in the gauge pod*)
- 4) Connect the fuel signal to the "S" terminal on the back of the FUEL gauge.
- 5) Connect the temperature signal to the "S" terminal on the back of the TEMPERATURE gauge.
- 6) Connect the oil pressure signal to the "S" terminal on the back of the OIL PRESSURE gauge.
- 7) The VOLT gauge does NOT require a signal and has had the "S" terminal removed to prevent damage to the gauge.

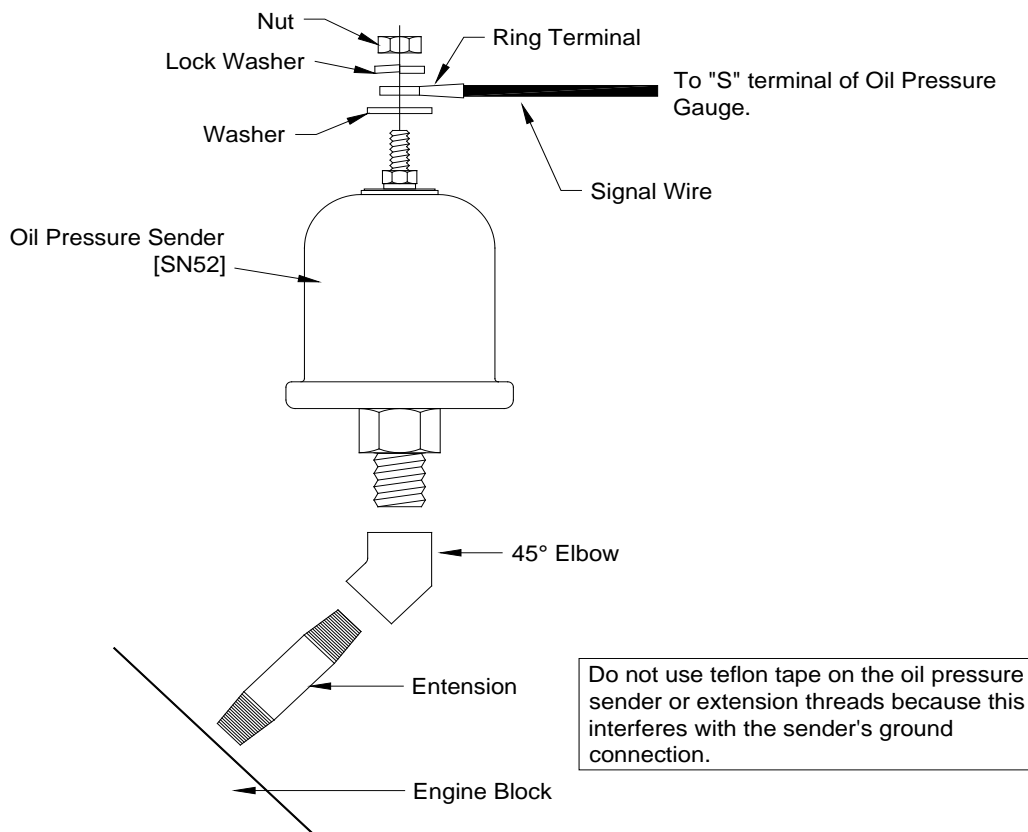

Oil Pressure Sender Wiring

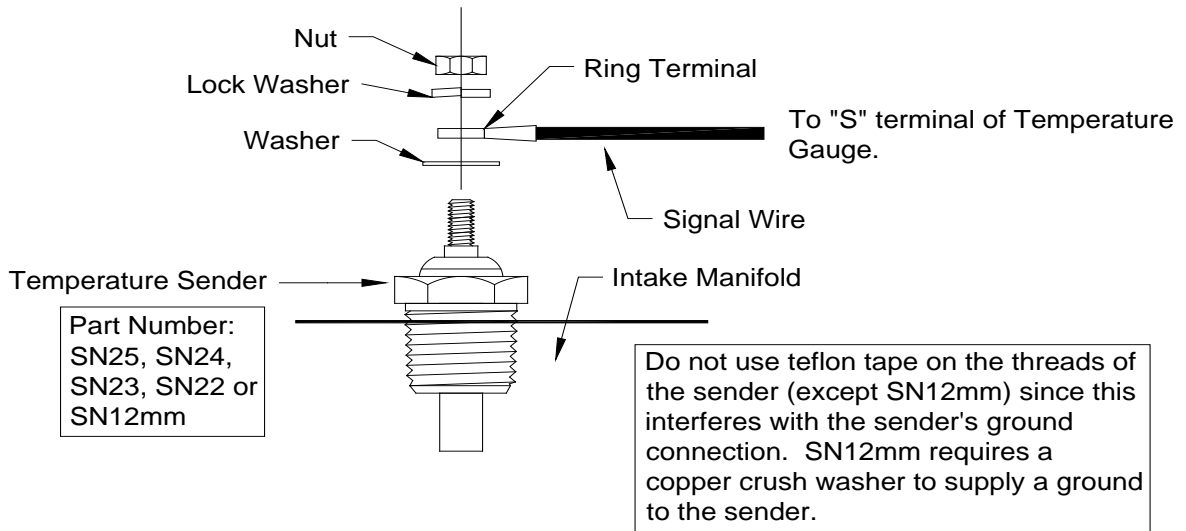

Temperature Sender Wiring

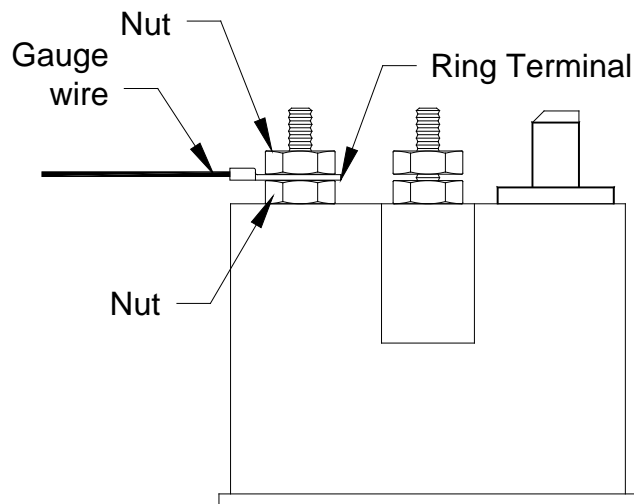
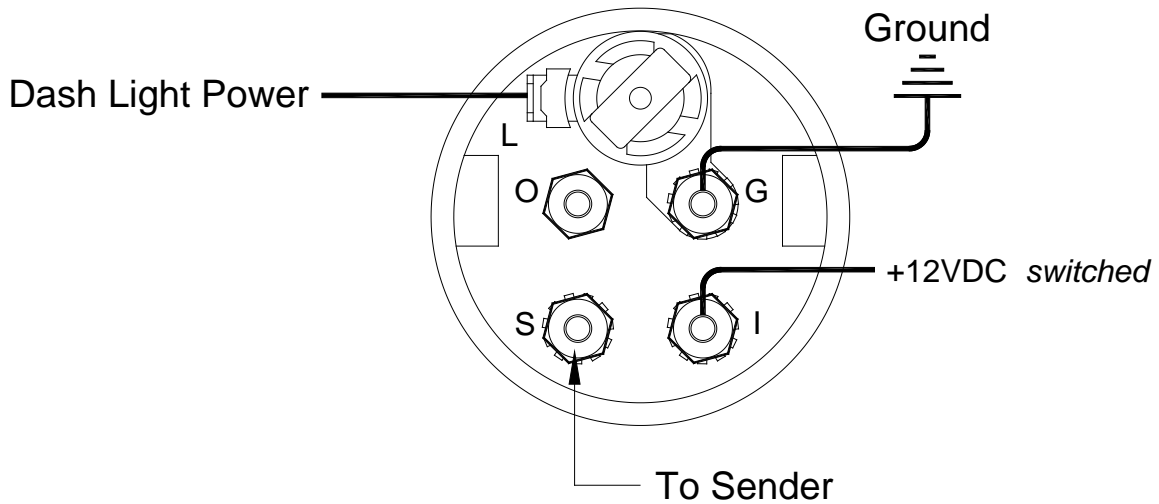

Fuel, Oil Pressure, Temperature, Volt Gauge Wiring

Universal Fuel Level Sender Installation

ADJUSTABLE FUEL LEVEL SENDER KIT

SN35 (240Ω-33Ω), SN36 (0Ω -30Ω), SN38 (0Ω -90Ω), SN39 (75Ω -10Ω) & SN40 (10Ω -180Ω)

| A = Tank Depth , B = Float Pivot Depth , C = Float Arm Length (Dimensions in Inches) | | | | | | | | |
|---|------|-----|------|------|------|------|-------|------|
| A | B | C | A | B | C | A | B | C |
| 6.0 | 3.0 | 3.5 | 12.0 | 6.0 | 7.8 | 18.0 | 9.0 | 12.0 |
| 6.5 | 3.25 | 3.8 | 12.5 | 6.25 | 8.1 | 18.5 | 9.25 | 12.3 |
| 7.0 | 3.5 | 4.2 | 13.0 | 6.5 | 8.5 | 19.0 | 9.5 | 12.6 |
| 7.5 | 3.75 | 4.5 | 13.5 | 6.75 | 8.9 | 19.5 | 9.75 | 12.9 |
| 8.0 | 4.0 | 4.9 | 14.0 | 7.0 | 9.3 | 20.0 | 10.0 | 13.4 |
| 8.5 | 4.25 | 5.3 | 14.5 | 7.25 | 9.6 | 20.5 | 10.25 | 13.8 |
| 9.0 | 4.5 | 5.6 | 15.0 | 7.5 | 10.0 | 21.0 | 10.5 | 14.2 |
| 9.5 | 4.75 | 6.0 | 15.5 | 7.75 | 10.4 | | | |
| 10.0 | 5.0 | 6.4 | 16.0 | 8.0 | 10.7 | | | |
| 10.5 | 5.25 | 6.7 | 16.5 | 8.25 | 11.0 | | | |
| 11.0 | 5.5 | 7.1 | 17.0 | 8.5 | 11.4 | | | |
| 11.5 | 5.75 | 7.4 | 17.5 | 8.75 | 11.8 | | | |

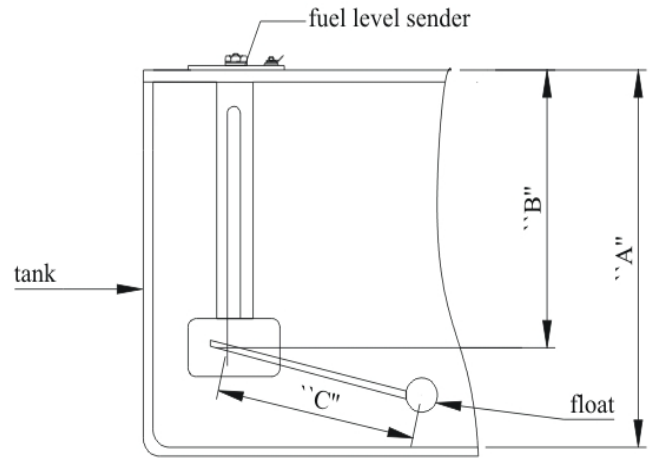

TABLE 1

I. Measure depth of the fuel tank. Locate this dimension in Column "A" of Table 1. Column "B" shows the length from the underside of the sender flange to the center of the float pivot. Column "C" shows distance from the center of the float pivot to the center of the float. For example, a tank 12" deep would need a measurement of 6" from the flange to the pivot and 7.8" from the pivot to the float.

II. For tank depths 6" to 15-1/2", it will be necessary to eliminate a part of the assembly. (See Fig.1) proceed as follows:

1. Remove two screws "d" and discard.
2. Remove two screws "e" from the plastic housing and reserve for later use.
3. Carefully remove bracket "f" from the plastic housing and discard. Replace with bracket "g" in the housing and loosely re-install the two screws "e" into housing.
4. Slide housing up or down until the proper dimension from Table 1 is reached, then tighten screws securely.

CAUTION: Do not over tighten hardware to avoid damage to the threads.

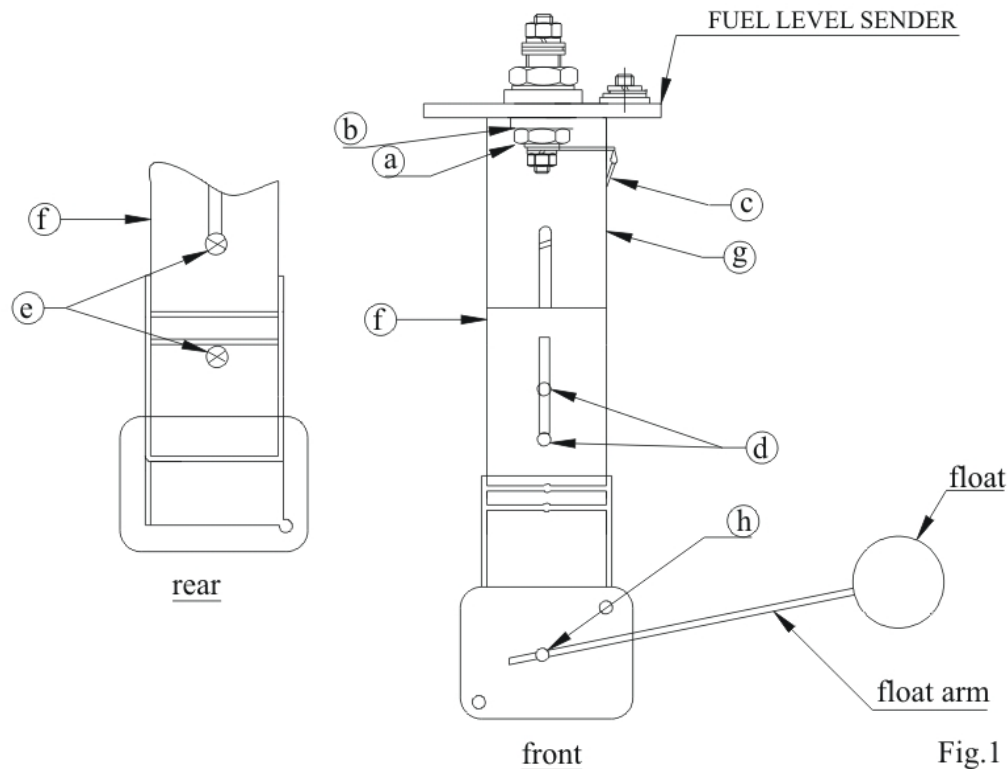

Fig.1

III. For tank depths of 16" to 21" no disassembly of the sender bracket is necessary.

1. Loosen two screws "d" and adjust the plastic housing up or down until the proper dimension from Table 1 is obtained, then retighten screws securely.

IV. To install the float assembly, loosen screw "h", remove the short piece of rod, and discard. Insert the float rod until the proper length "c" from Table 1 is met, and then tighten the screw securely. Carefully cut off any excess rod with bolt cutter or similar tool, taking care not to damage the assembly.

NOTE: Make sure the float is installed as shown in Fig.1. If installed backwards, the fuel gauge will indicate "full" when the tank is empty, and "empty" when the tank is full.

1. Cut the sender bracket so it doesn't extend lower than the black rheostat assembly. The rheostat should be the lowest point of the fuel sender.
2. With the gasket in place below the flange, carefully feed the float arm and sender body into the 1.697" (43mm) hole in the tank. Make certain the float arm has free motion within the tank. Using the sender flange as a template, locate the position of the five mounting holes. Use the supplied screws to mount into the tank with threaded inserts in place.
3. Insert fuel sender assembly into tank, align holes and thread in mounting screws. Check that all screws are secure to complete assembly.
4. Connect the center terminal of the sender to your fuel gauge's signal terminal. Connect the off-center terminal to a good chassis ground.

AVOID OVERTIGHTENING.

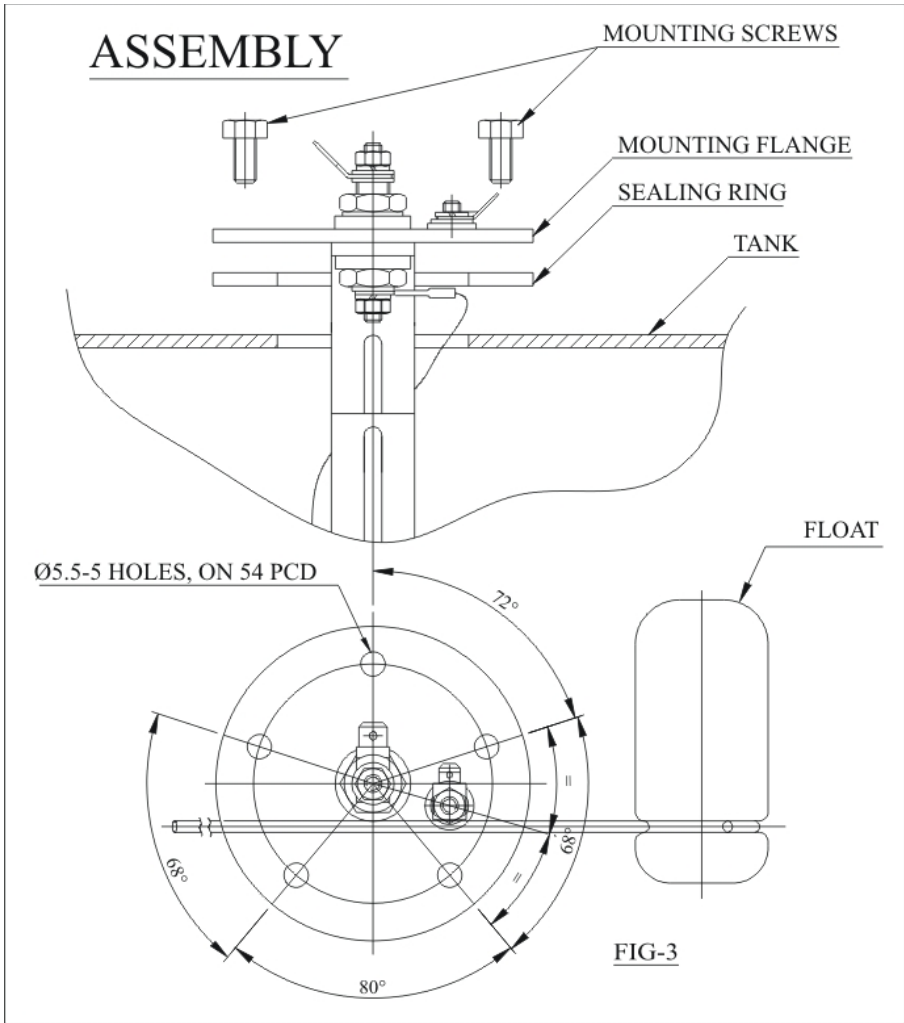

Happy Hot Rodding!